



Pneumatic Torque Wrench
 Reversible non-Impacting
A Controlled Bolting Solution

3/4", 1" & 1 1/2" Square Drives offer Smooth Continuous Rotation from 200 ft lbs to 11,500 ft lbs

Most advanced **Planetary Gear** reduction Gearbox driven by a precision air motor.

Precision Spline gives 360° reaction arm placement & nose extension control.

Automatic 2 Speed gearbox Models for high-speed rundown and single sequence precision tightening.

Reaction Arm Range adaptable to every situation.

Simple Pistol Grip Trigger & Reverse Switch operation

Low Noise, High Power-to-Weight ratio reducing operator strain. 88x less vibration than Rattle Guns with Zero hammering!

Unmatched Power & Reliability capable of accuracy of +/-5%, & repeatability of +/-2%.

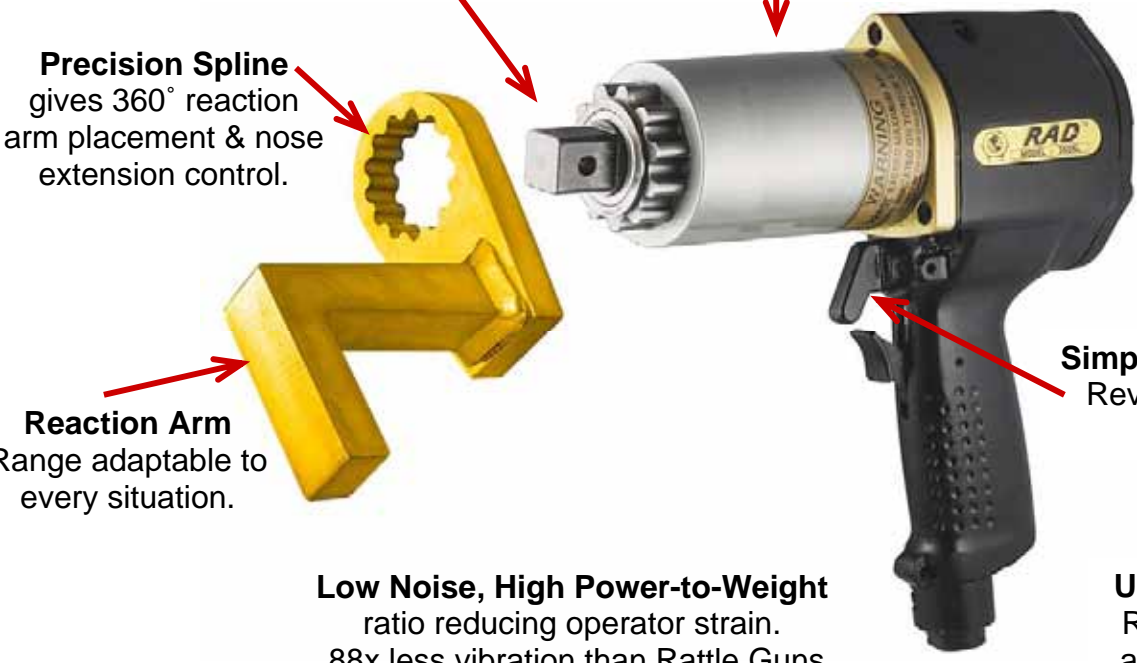

Complete with:
 Cradle + Hose
 Regulator + Lubricator

Range covers **Pneumatic, Electronic, Electric, and Battery powered** Tools offering a complete solution



Pneumatic Torque Nut Runner Tools

Fast - Light Weight - Accurate - Low Vibration - Simple to Use - Affordable - Quiet

RAD PNEUMATIC TORQUE TOOLS -Single Speed

Photo	Part Number	Model	Sq Drive	Torque Ft Lbs	Torque NM	RP M	Weight
	12316	350SL	3/4"	50 -350	70 -475	65	2.7 kg
	12321	550SL	3/4"	100 -550	150 -750	35	2.9 kg
	12814	7GX	3/4"	100 -700	130 -950	30	3.6 kg
	12818	10GX	3/4"	200 -1000	270 -1,350	20	3.6 kg
	17328	15DX	1"	300 -1,500	400 -2,000	15	5.6 kg
	12345	2000	1"	500 -2,000	700 -2,700	13	5.8 kg
	12377	25GX	1"	500 -2,500	700 -3,400	8	6.1 kg
	12356	34GX	1"	1000 -3,400	1,400 -4,600	12	9.0 kg
	12357	50	1-1/2"	1,500 -5,000	2,000 -6,800	7	12.7 kg
	15328	60DX	1-1/2"	2,000 -6,000	2,700 -8,130	6.6	12.7 kg
	12383	85GX	1-1/2"	3000 -8,500	4,070 -11,520	4.5	17.4 kg



RAD Air Nut Runners -Perfect solution to ensure correct torque.

Improve **Safety**, apply a **known torque value -fast**

Decrease downtime -**Easy to use** -non complicated - Full power in reverse for **loosening** tight nuts -**no electricity required**. RAD Pneumatic torque Tools use shop air 90 to 100 psi (25-35 cfm) To set the torque simply adjust the air regulator, full torque control, set and forget. The tool will stall when torque is reached. The RAD torque tools replace rattle guns and torque multipliers -**Non Impacting** -No need for any more guessing or risk taking during maintenance.



Pneumatic Wrench NX Tool Kits

Non Impacting Tool

Zero Hammering
or Vibration

High RPM -

Reduce Bolting Time

Controlled Torque -

Smooth Continuous Flow
from 100 to 2500 ft lbs

Accuracy - +/- 5%
Reduced Noise
Levels - 80 db.



Multiple Applications

3 Reaction Arms
+ Nose Extension



Comes in tough
dustproof & waterproof case

Complete with
Cradle + Hose
+ Regulator
+ Lubricator



Halve your time on common maintenance tasks!

Packaging your RAD Tool of choice with a Nose Extension
& 3 Reaction Arms covers almost every bolting applications

Powerful Ergonomic Safe Reliable



Loaders

Dozers

Articulated Trucks

Excavators

Part Number	Tool Model	Torque		Speed RPM	Nose Extension
		Ft.lbs	NM		
15517	7GX-NX	100-700	135-950	30	12"
13691	10GX-NX	200-1000	270-1350	20	12"
15518	1400NG-NX	300-1400	400-1900	15	12"
15519	1400NG-2-NX	500-1400	700-1900	69	12"
15520	1800NG-NX	500-1800	700-2450	10	12"
15521	1800NG-2-NX	700-1800	950-2450	53	12"
15522	25GX-NX	500-2500	700-3400	8	18"

